

260 GALLON RECEIVER

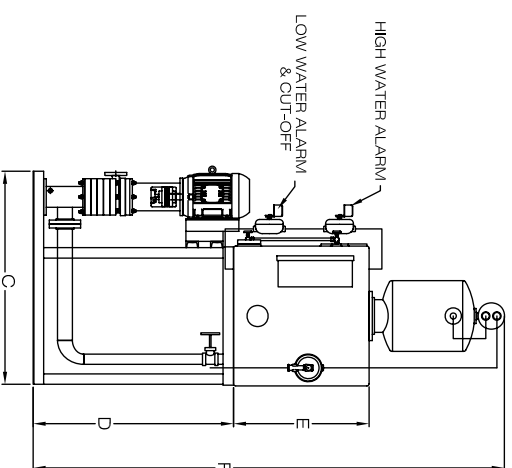
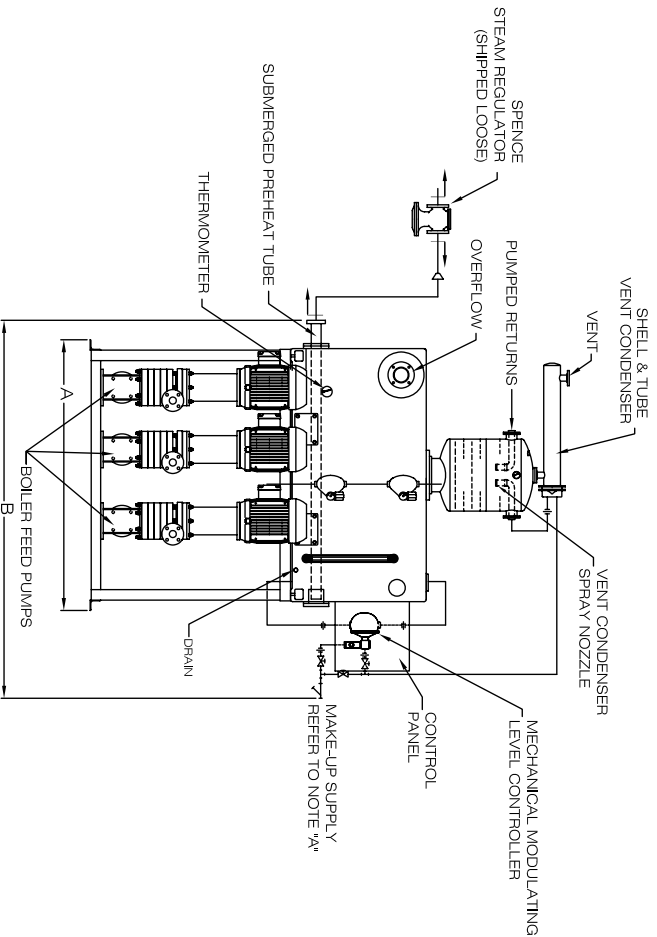

DRAWING FOR REFERENCE USE ONLY

INDICATES WHERE SHIPCO PIPING ENDS

ALL DIMENSIONS ARE APPROXIMATE

NOTE "A"

MAKE-UP CONNECTION IF SINGLE TANK DESIGN
TRANSFER CONNECTION IF TWO TANK DESIGN

50 TO 150 BOILER HORSEPOWER - 260 Gallon Cast Iron Receiver - 8,625 lbs./Hr. Steam*

ALL DIMENSIONS APPROXIMATE

GALLONS	A	B	C	D	E	F	DRAIN	OVERFLOW	VENT
260	70"	96"	52"	48"	33"	142"	3/4" NPT.	2 1/2" FLG.	2" FLG.

Dimension "C" may vary based on pump model selection

SHIPCO[®]
PUMPS

MANUFACTURED BY

SHIPPENSBURG PUMP COMPANY INC.

P. O. Box 279 Shippenburg, Pa. 17257

PHONE 717 532-7321 / FAX 717 532-7704

WWW.SHIPCOPIUMPS.COM

SHIPCO[®] IS A REGISTERED TRADEMARK OF SHIPPENSBURG PUMP CO., INC.

.005 DA-CI 260 GAL 50-150 BHP
ATMOSPHERIC DESIGN
VERTICAL PUMPS

DRAWN BY S.A.D. DATE 6/09 REVISION .2

DIMENSION PRINT# 40286

Section .005 A DA Page 1400