

260 GALLON RECEIVER

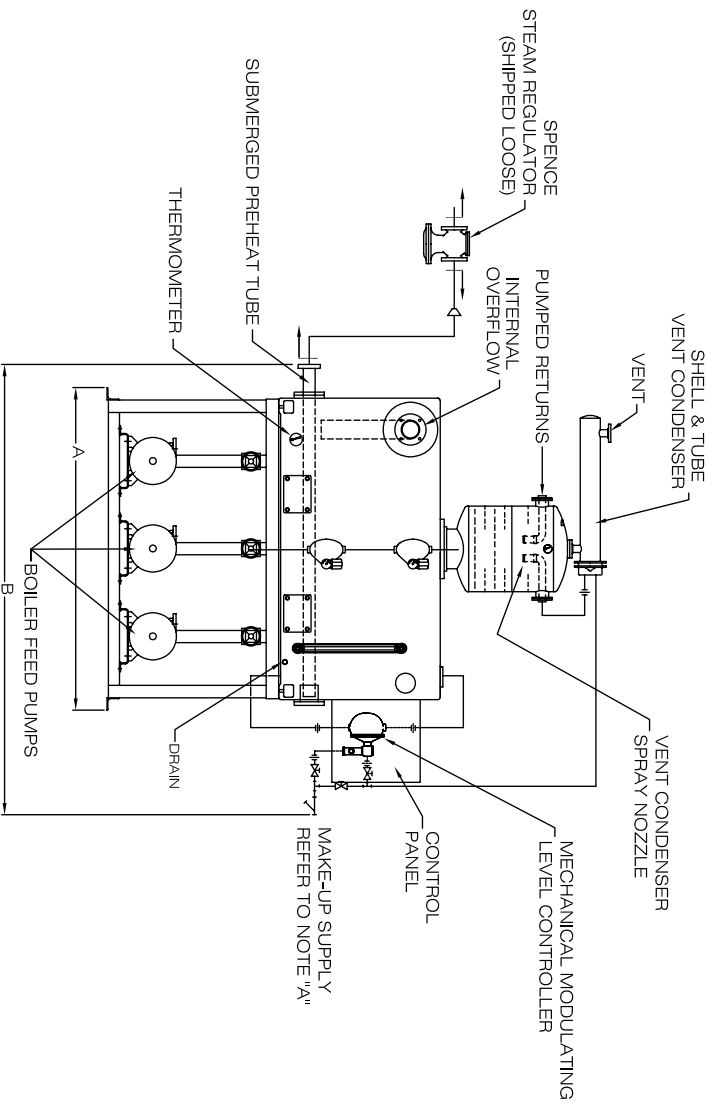

DRAWING FOR REFERENCE USE ONLY

INDICATES WHERE SHIPCO PIPING ENDS
 "ALL DIMENSIONS ARE APPROXIMATE"

NOTE "A"
 MAKE-UP CONNECTION IF SINGLE TANK DESIGN
 TRANSFER CONNECTION IF TWO TANK DESIGN

ALL DIMENSIONS APPROXIMATE

GALLONS	A	B	C	D	E	F	DRAIN	OVERFLOW	VENT
260	70"	96"	74"	48"	33"	142"	3/4" NPT.	2 1/2" FLG.	2" FLG.

Dimension "C" may vary based on pump model selection

50 TO 150 BOILER HORSEPOWER - 260 Gallon Cast Iron Receiver - 8,625 lbs./Hr. Steam *

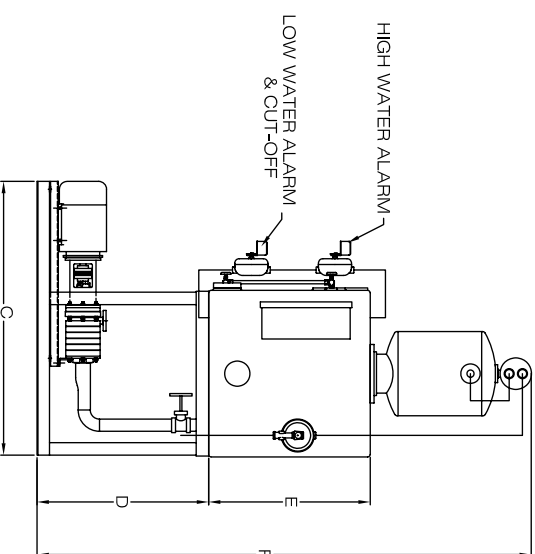

SHIPCO®
 SHIPCO PUMPS

MANUFACTURED BY
 SHIPPENSBURG PUMP COMPANY INC.
 P.O. Box 279 Shippensburg, Pa. 17257
 PHONE 717 532-7321 / FAX 717 532-7704
 WWW.SHIPCO.PUMPS.COM

SHIPCO® IS A REGISTERED TRADEMARK OF SHIPPENSBURG PUMP CO., INC.
 .005 DA-CI 260 GAL 50-150 BHP
 ATMOSPHERIC DESIGN
 HORIZONTAL PUMPS

DRAWN BY	DATE	REVISION
S.A.D.	6/09	.2
DIMENSION PRINT#	40288	