

500 GALLON RECEIVER

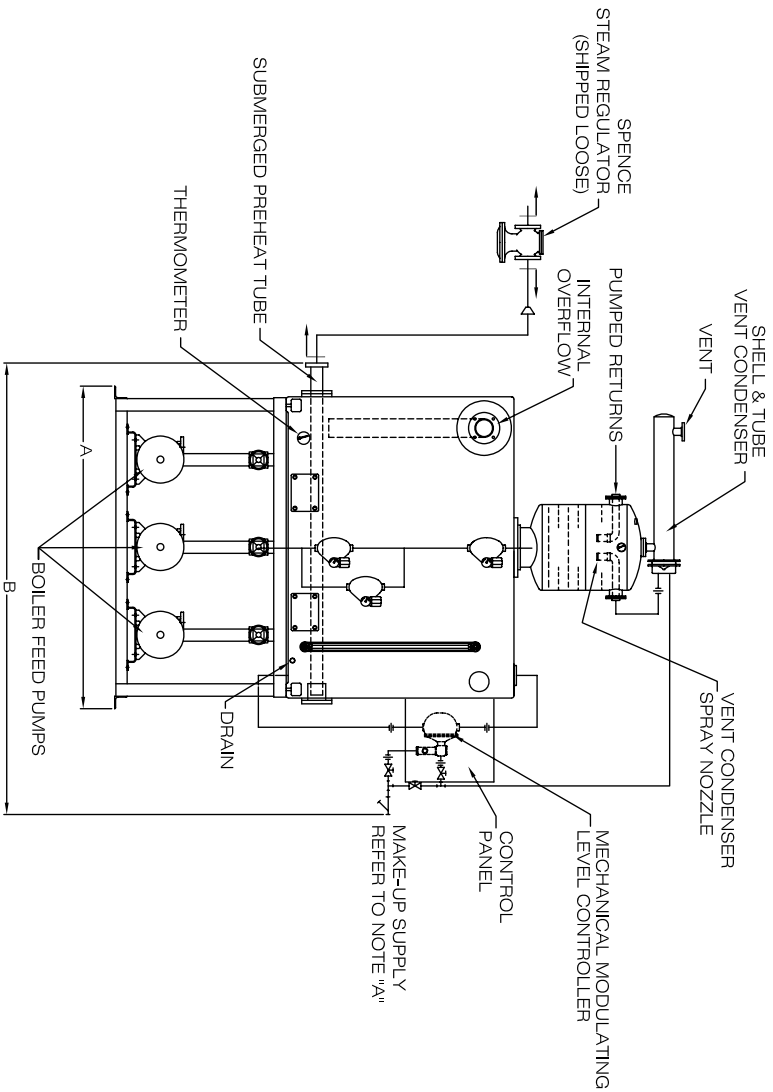

DRAWING FOR REFERENCE USE ONLY

INDICATES WHERE SHIPCO PIPING ENDS

"ALL DIMENSIONS ARE APPROXIMATE"

NOTE "A"

MAKE-UP CONNECTION IF SINGLE TANK DESIGN
TRANSFER CONNECTION IF TWO TANK DESIGN

50 TO 150 BOILER HORSEPOWER - 500 Gallon Cast Iron Receiver - 17,500 lbs./Hr. Steam*

ALL DIMENSIONS APPROXIMATE

GALLONS	A	B	C	D	E	F	DRRAIN	OVERFLOW	VENT
500	82"	110"	74"	48"	48"	168"	1" NPT.	3" FLG.	3" FLG.

Dimension "C" may vary based on pump model selection

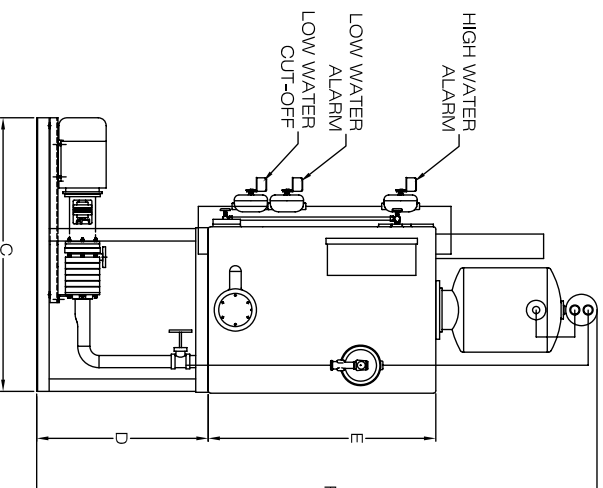

SHIPCO[®]
PUMPS

MANUFACTURED BY

SHIPPENSBURG PUMP COMPANY INC.

P.O. Box 279 Shippensburg, Pa. 17257

PHONE 717 532-7321 / FAX 717 532-7704

WWW.SHIPCO.PUMPS.COM

SHIPCO[®] IS A REGISTERED TRADEMARK OF SHIPPENSBURG PUMP CO., INC.

.005 DA-CI 500 GAL 50-150 BHP
ATMOSPHERIC DESIGN
HORIZONTAL PUMPS

DRAWN BY S.A.D. DATE 6/09 REVISION .2

DIMENSION PRINT# 40292