

-INSTALL ALL DRAIN PIPING FULL SIZE TO AIR GAP OR OPEN DRAIN
 -UNIT IS NOT DESIGNED TO SUPPORT PIPING.
 -ALL CONNECTING PIPING MUST BE FIELD SUPPORTED & ANCHORED.

D	L	GAL.	INLET	OVERFLOW	VENT	DRAIN	MAKE UP	A	B	C	E
19	24	29	2 1/2 NPT	2 NPT	2 NPT	1/2 NPT	3/4 NPT	16 5/8	36	16 3/8	18 7/8
24	36	70	2 1/2 NPT	2 NPT	2 NPT	1/2 NPT	3/4 NPT	21 3/4	48	21 1/2	24
24	48	94	2 1/2 NPT	2 NPT	2 NPT	1/2 NPT	3/4 NPT	21 3/4	60	21 1/2	24
24	60	117	2 1/2 NPT	2 NPT	2 NPT	3/4 NPT	3/4 NPT	21 3/4	72	21 1/2	24
30	48	147	3 NPT	2 NPT	2 NPT	3/4 NPT	3/4 NPT	27 3/4	60	27 3/8	30
30	60	183	3 NPT	2 NPT	2 NPT	1 NPT	3/4 NPT	27 3/4	72	27 3/8	30
30	72	220	4 NPT	2 NPT	2 1/2 NPT	3/4 NPT	3/4 NPT	27 3/4	84	27 3/8	30
36	60	264	4 NPT	2 1/2 NPT	2 1/2 NPT	3/4 NPT	3/4 NPT	32 7/8	72	32	36
36	72	317	4 NPT	2 1/2 NPT	2 1/2 NPT	3/4 NPT	3/4 NPT	32 7/8	84	32	36
36	84	370	4 NPT	2 1/2 NPT	2 1/2 NPT	3/4 NPT	3/4 NPT	32 7/8	96	32	36
42	72	432	4 NPT	2 1/2 NPT	2 1/2 NPT	3/4 NPT	1 1/4 NPT	39 1/4	84	38 7/16	42
42	84	504	4 NPT	2 1/2 NPT	3 NPT	1 NPT	1 1/4 NPT	39 1/4	96	38 7/16	42
42	96	576	4 NPT	2 1/2 NPT	3 NPT	1 NPT	1 1/2 NPT	39 1/4	108	38 7/16	42
48	84	658	6 FLG	2 1/2 NPT	3 NPT	1 1/2 NPT	1 1/2 NPT	44 7/16	96	42 1/2	48
48	96	752	6 FLG	2 1/2 NPT	3 NPT	1 1/2 NPT	1 1/2 NPT	44 7/16	108	42 1/2	48
48	120	940	6 FLG	2 1/2 NPT	3 NPT	1 1/2 NPT	2 NPT	44 7/16	132	42 1/2	48
54	120	1190	6 FLG	3 NPT	3 NPT	1 1/2 NPT	2 NPT	50 7/16	132	49 1/4	54
60	120	1468	6 FLG	3 NPT	3 NPT	1 1/2 NPT	2 NPT	56 7/16	132	55 1/4	60

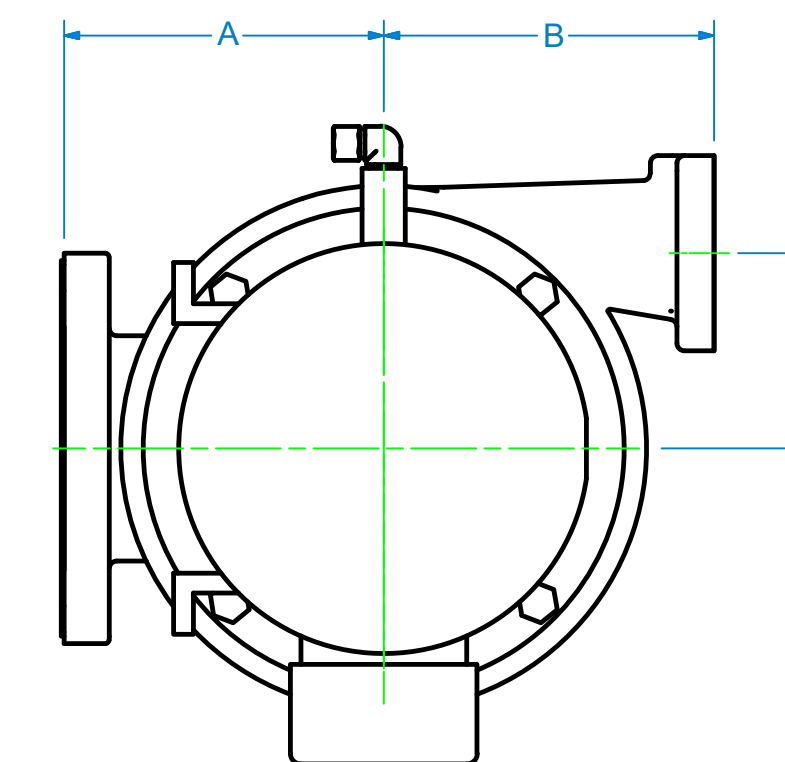

NOTE: A = 0 FOR ALL END SUCTION PUMPS

MODEL	A	B	C
106-D	4 3/4	4	3 1/2
110-D	4 3/4	4 1/4	0
113-D	5 3/8	5 7/16	3 1/4
114-D	7	6 3/4	3 1/4
116-D	5 3/8	8 3/8	3 1/4
116-AWF	6 9/16	5 7/8	3 1/8
117-D	5 3/8	5 7/16	-9/16
121-D	5 3/8	6 11/16	-9/16
121-AW	0	6 3/4	3 3/4
127-D	5 3/8	6 11/16	3 1/4
128-D	7	3 13/16	5
129-D	7	6 3/4	5
129-AW	0	8 1/4	5
130-D	7	6 3/4	5
130-AW	0	8 1/4	5
131-D	7	6 3/4	5 3/4
132-D	8 1/2	8	6 3/8
133-AW	8 1/2	9 1/8	5 3/4



SHIPPENSBURG PUMP CO., INC.

P.O. Box 279 Shippensburg, PA 17257
 (717) 532-7321 • www.shipcopumps.com

SHIPCO® is a registered trademark of Shippensburg Pump Co., Inc.

CYLINDRICAL STEEL BOILER FEED UNIT

SECTION	DRAWING NO.	REV.	DATE
CS	TK-CS-LIT	1	7/26/2023