

SHIPCO[®]
PUMPS

SHIPPENSBURG PUMP CO., INC.
P.O. BOX 279, SHIPPENSBURG, PA 17257
PHONE 717-532-7321 • FAX 717-532-7704
WWW.SHIPCO PUMPS.COM

PRIDE

QUALITY

CRAFTSMANSHIP

BULLETIN 148
Revised 5/09

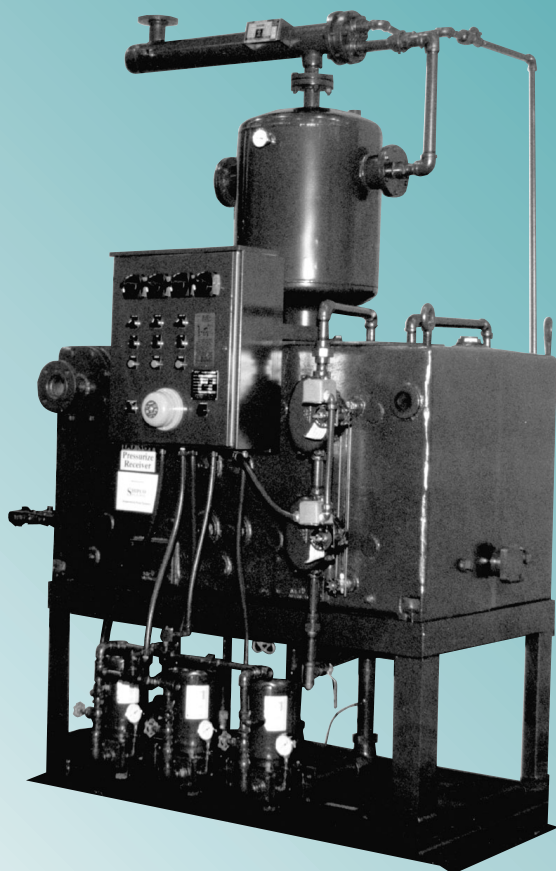

TYPE .005 DA-CI

Spray Tray Deaerating
Boiler Feed Pumps
with Cast Iron Receiver

and

TYPE .005 DA-CI-2T

when separate surge tank is utilized

SHIPCO[®] Deaerators can save you money!!!

SHIPCO[®]
PUMPS are equipped with Mechanical Seals rated for temperatures
up to 300°F as standard.

.005 DA-CI DEAERATING BOILER FEED PUMPS

SHIPCO®'s deaerators are designed to remove the non-condensable gases from boiler feed water. To understand the process, it is helpful to understand two basic gas laws. Henry's Law and Dalton's Law of Partial Pressures are primary rules to understand.

Henry's Law, credited to William Henry, an English Chemist (1775-1836), states that: "The solubility of gases in liquids is directly proportional to the pressure of the gas above the liquid." This law simply states that if the pressure of a gas above a liquid is increased more gas dissolves in the liquid. It is important to understand that there is constant motion of gas molecules dissolved in a liquid. The state of equilibrium is when the number of molecules leaving the surface area equals the number of molecules entering the surface area.

Henry's Law can literally be demonstrated with the effervescence that occurs when you open a carbonated beverage. The carbon dioxide in the beverage is forced into the liquid and bottled under pressure. When the cap is removed, the pressure is reduced and the dissolved carbon dioxide escapes from the liquid to reach an equilibrium at atmospheric pressure.

Oxygen is only slightly soluble in water. Carbon dioxide is more soluble in water and reacts with the water to form carbonic acid. The reaction that occurs is usually a result of the bicarbonate and carbonate alkalinity of the raw make-up water being heated. Heating the alkaline make-up water causes free carbon dioxide to be released which readily forms carbonic acid. It is important to eliminate the carbon dioxide from the feed water as a gas. Once carbonic acid is formed, it builds in concentration. The acid is more difficult to remove from the feed water than the gases.

Carbonic acid can be credited with the thinning of pipes and the grooving that occurs along the bottom of return lines.

Our atmosphere is a mixture of different gases. Understanding Dalton's Law of Partial Pressures is important when a mixture of gases is present. Dalton's Law of Partial Pressures states that: "The total pressure exerted by a mixture of gases is equal to the sum of the partial pressures of the various gases comprising the mixture." This law simply states that each gas in a mixture acts as if it were alone in the space; however, the total pressure is the sum of all the partial pressures of all the gases in the mixture.

Our atmosphere is a mixture of gases. Understanding Henry's Law and Dalton's Law of Partial Pressures allows us to see that the dissolved gases in our make-up water are proportional to the partial pressures exerted by the gases in our atmosphere. Our air is about 20 percent oxygen. The amount of dissolved oxygen in make-up water is directly proportional to the partial pressure exerted by the oxygen (gas) in the atmosphere at a definite temperature and at a fixed volume.

Oxygen solubility in water is in direct relationship with the water temperature. (see chart)

Raising the temperature of feed water increases the speed of the molecules in it. Applying Henry's Law, the number of molecules leaving the surface area is greater than the number of molecules entering the surface area, lowering the concentration as heat is applied. This process is enhanced by increasing the surface area of the exposed feed water. This is accomplished by the use of spray nozzles and cascade trays.

Refer to the Oxygen Solubility Chart and note the oxygen solubility at 212°F at atmospheric pressure. The chart then shows pressures greater than atmospheric pressure and less than atmospheric pressure. In all cases, at the saturation temperature the oxygen constant is zero. All deaerators, regardless of design, must conform to this physical law.

The design of a deaerator relies on expanding the surface area of the feed water to obtain the release of the non-condensable gases. The atmospheric design allows a free flow of gases while a pressurized design uses a restricted orifice method. The atmospheric design lends to the use of vent condensers for increased operating efficiency. Either design may obtain the desired results.

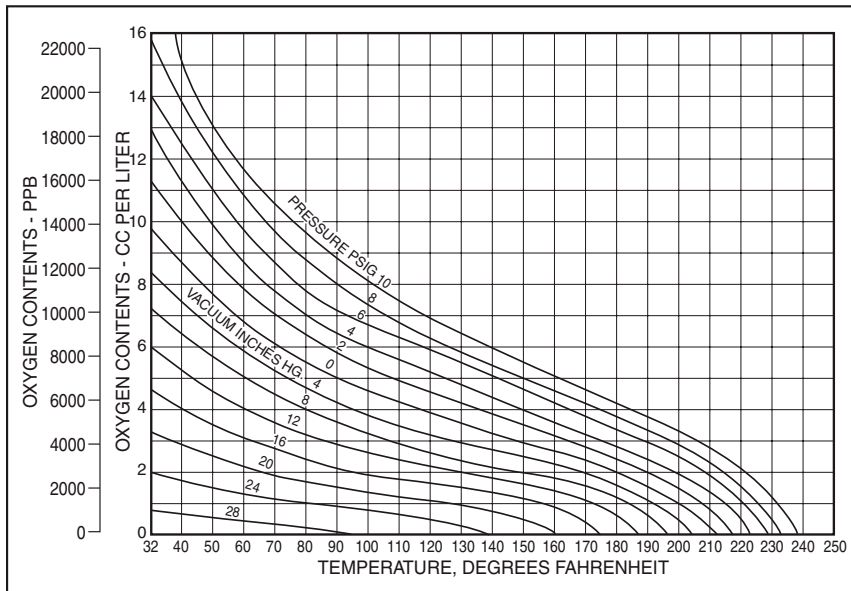

OXYGEN SOLUBILITY IN WATER AT VARIOUS TEMPERATURES AND PRESSURES

Steam is the gaseous form of water. Dalton's Law of Partial Pressures allows the definition of boiling point to be "The condition when the equilibrium vapor pressure of a liquid is equal to the prevailing atmospheric pressure." This means that the number of molecules leaving the surface area equals the number entering.

We are now ready to study the difference between deaerators operated at atmospheric pressure (14.92 PSI) and those operated at a gauge pressure above one (1) atmosphere. (Note: 5 PSIG is a nominal set operating pressure.) For our discussion we will refer to units operating at atmospheric pressure as "atmospheric" deaerators and those operating at pressures greater than one (1) atmosphere as "pressurized" deaerators.

An atmospheric deaerator now allows the free oxygen and carbon dioxide to be vented to the atmosphere and with the use of a vent condenser, capture the waste heat. An atmospheric deaerator has a saturation temperature of 212°F. A pressurized (5 PSIG) deaerator has a saturation temperature of 227°F. At either fixed temperature the solubility of O₂ is a constant.

Having reviewed the specific gas laws that apply to the deaeration process, we are now ready to look at the mechanical processes of deaeration. The Oxygen Solubility Chart is again referred to for our discussion. The amount of dissolved oxygen in feed water is a function of temperature. Maintaining saturation temperature is accomplished by injecting steam into the feed water. The steam is injected below the water line, causing the bubbles to agitate the deaerated water to prevent reabsorption. The steam then

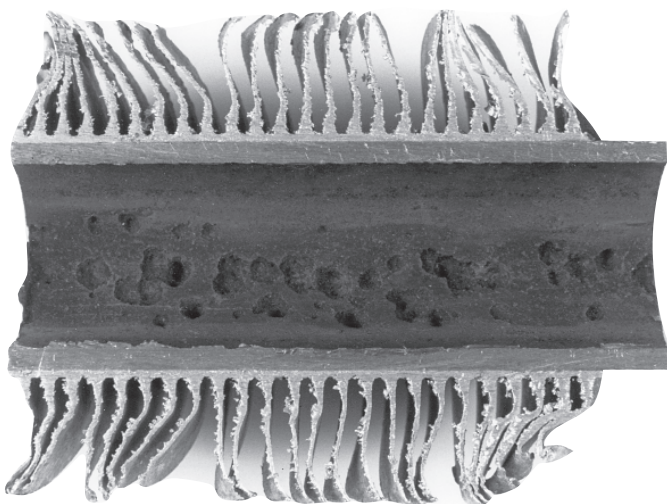

**OXYGEN PITTING IS A COSTLY PROBLEM!
 PROPER WATER TREATMENT UTILIZING MECHANICAL
 DEAERATION IS VERY INEXPENSIVE WHEN COMPARED
 TO REPLACING EQUIPMENT PREMATURELY!**

enters the open area of the storage receiver. The free steam is now in contact with the cascading water from the tray section of the deaeration column. This water is at saturation temperature and being deaerated a second time. Free steam continues rising to the spray section of the Deaeration Dome. Here the feed water enters the Dome through a spray nozzle and is raised to saturation temperature.

In atmospheric units, the temperature sensing element controlling the steam inlet valve is located below the water line. This location ensures a steam flow at the various load swings. The steam is in sufficient supply to effect an instantaneous temperature change to the saturation temperature. The release of the non-condensable gases is accomplished at this point.

With atmospheric units, a shell and tube vent condenser is installed on the vent connection of our atmospheric style deaerators. The steam vapor is condensed and the latent heat is used to preheat the incoming feed water. The vent is sized to allow a free venting of the uncondensable gases. Under operating conditions, only trace amounts of steam appear to flow from the vent line.

Pressurized units are controlled by a steam pressure pilot. The internal working pressure of the receiver is maintained at 5 PSIG. The steam temperature and pressure are in direct relationship, hence you maintain saturation temperature.

It is a commonly recognized fact that using a deaerator can save hundreds of dollars and lower fuel costs. Using atmospheric deaerator designs results in the greatest overall operating efficiency.

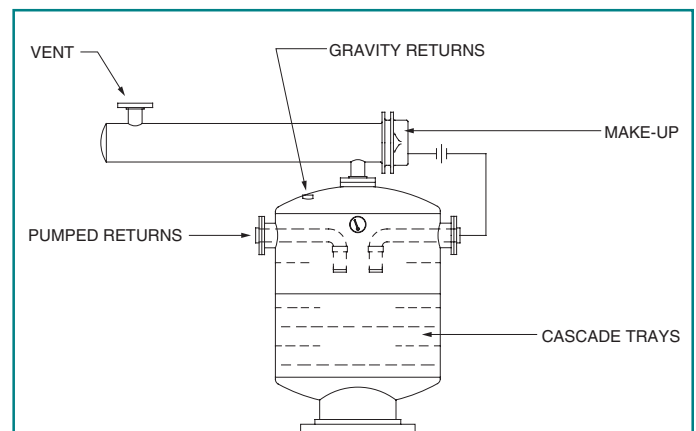

SHIPCO®'s Deaeration Dome is a spray-tray design. The initial atomization occurs with the spray and is enhanced with the cascade stainless steel trays. This atmospheric dome allows the released gases to escape through the vent. Our design allows for the free release of the entire storage while permitting only a minimal vent loss by using a vent condenser.

MECHANICAL DEAERATION IS A COST EFFECTIVE MEANS TO ACHIEVE EFFICIENT BOILER PLANT OPERATION.

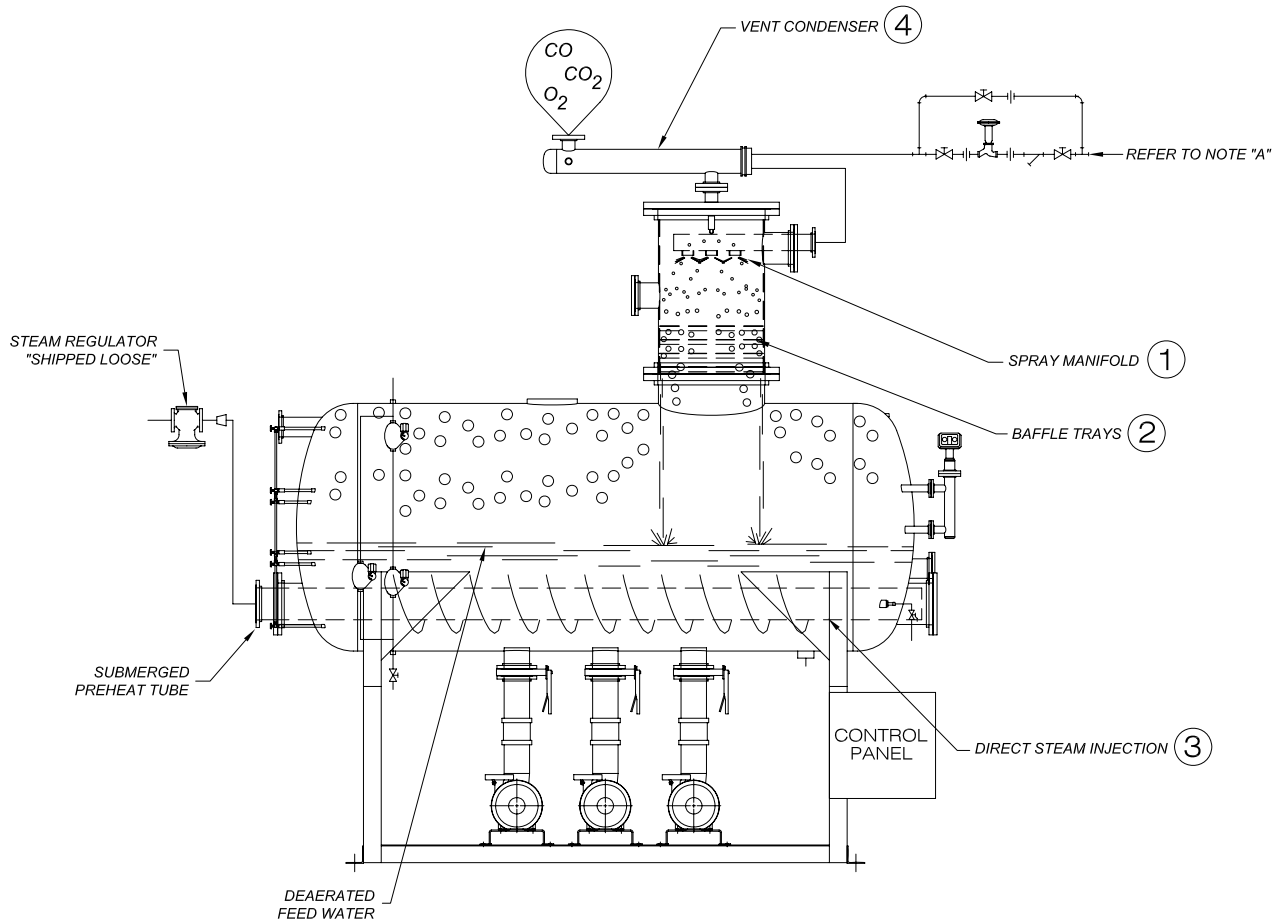

NOTE "A"
MAKE-UP CONNECTION IF SINGLE TANK DESIGN
TRANSFER CONNECTION IF TWO TANK DESIGN

SHIPCO® has a four-step approach.

1. Incoming feed water is introduced into the deaeration dome by stainless steel spray nozzles. The fine spray provides the increased surface area for heat absorption and release of the non-condensable gases.
2. The falling droplets of feed water next form a film to cascade down the tray section of the deaeration dome. Maintaining a thin film keeps the surface area exposed for steam scrubbing.
3. Directly injecting the steam into the deaerated feed water holding section provides a continuous steam scrubbing, preventing re-absorption of the non-condensables.
4. The vent condenser allows gases to escape through the vent with only a minimal loss and pre-heats the make-up water going into the DA unit.

SHIPCO® DEAERATORS CAN SAVE YOU MONEY COMPARED TO LOST PRODUCTION TIME AND EXPENSIVE REPAIR OR REPLACEMENT OF PREMATURELY CORRODED BOILERS, BOILER TUBES, CONDENSATE RETURN LINES, HEAT EXCHANGERS, OR PROCESS EQUIPMENT.

SHIPCO® DEAERATORS CAN SAVE YOU MONEY COMPARED TO REDUCED CAPACITY OF THERMAL EQUIPMENT.

Deaerator Boiler Feed Pump Selection & Sizing

Selection is based on gallons per minute (GPM), pounds per square inch (PSIG), net positive suction head (NPSH) and receiver size.

Determine GPM

The evaporation rate of one boiler horsepower is .069 gallons per minute.

Other conversion equivalents: One boiler horsepower equals 33,475 BTU/hr. or 34.5 lbs./hr. or 139.4 sq. ft. EDR.

Boiler feed pumps for on-off operation are sized at two (2) times this evaporation rate.

Boiler feed pumps for continuous operation (generally 15 motor HP and larger) are sized at one and a half (1½) times this evaporation rate. In addition, extra flow for recirculation with deaerator boiler feed pumps may have to be added. The SHIPCO® centrifugal Model “P” and “D” pumps do not require any additional flow. SHIPCO® pumps with motors 5 HP and less have a bleed line that serves this function, and in pumps with motors 7½ HP and larger a bypass orifice is used in a recirculation line for this purpose.

Boiler feed pumps are sized based on the maximum number of boilers each pump is feeding.

Determine PSIG

The deaerator boiler feed pumps are sized to overcome the **operating** pressure of the boiler + friction loss in pipe + valve loss + feed valve loss (if any) + stack economizer (if any) + vertical lift from pump to boiler + safety margin of approximately 10 PSIG. The amount of these values added together, are normally expressed in feet of head. To convert feet of head to PSIG, 2.31 ft. = 1 PSIG.

Generally, the feed valve loss is 20 PSIG and the stack economizer loss is 20 PSIG when estimating the pump discharge pressure. Stack economizer requires a continuously running pump in the system.

The standard rules of thumb are:

- High-pressure boilers running on–off from a boiler level controller add 20 PSIG to the operating pressure (not the design pressure).
- High-pressure boilers running continuously pumping through a modulating valve add 30 PSIG to the operating pressure (always better to get pressure drop through valve).
- High-pressure boilers running continuously pumping through a modulating valve and a stack economizer add 50 PSIG to the operating pressure.
- Low-pressure boilers (running between 1 to 15 PSIG) generally use pumps with a discharge pressure of 20 PSIG.

If the boilers run at more than one pressure setting (like a night setback), an additional pump(s) is

needed to handle this pressure and the steam control regulator must be sized for this nighttime low-pressure setback.

Determine NPSH

NPSH stands for Net Positive Suction Head. The **available NPSH** is essentially the measure of how close the water in the suction passage of the pump is to boiling, with the attendant formation of steam within the impeller, thus diminishing the pump’s performance.

Since we have a deaerator where the water is at the saturation point or boiling point, the **available NPSH** is at zero, located at the bottom of the steam manifold.

Various physical designs of pump have various **NPSH requirements**. In order for any pump to operate successfully, the NPSH **available** must be **greater** than the NPSH **requirements**. With a deaerator the only way you can increase the NPSH available is to elevate the tank a greater distance than the pump requires. For example, a pump with an NPSH requirement of 4 ft. must be elevated at least 4 ft. plus a safety factor (usually 1 to 2 ft.). The SHIPCO® model “P” pump requires only 2 ft. of NPSH at the best efficiency point; therefore, our standard elevation is 4 ft. or 48 inches.

Suction strainers hurt NPSH calculations since you can’t measure the pressure drop through a strainer. In addition, if it works it will destroy the pump by causing it to run dry. For this reason suction strainers are **never** used with centrifugal pumps like the SHIPCO® model “P” or “D” pumps. Suction strainers are only used when turbine pumps are supplied since even a little dirt and debris will cause this style of pump to go bad due to the close tolerances within the design. The standard rule of thumb is to add one additional foot of stand elevation to compensate for this suction strainer.

Determine Receiver Size

The receiver size on a deaerator is based on the total load of all boilers being fed by the unit at any one time. The receiver size is generally based on 10 minutes of net storage when using a single compartment with returns.

If the system utilizes a surge tank with the deaerator, then the surge tank will be sized to handle the 10 minutes of net storage time required, with the deaerator being sized for only 5 minutes of net storage.

A deaerator without returns (100% make-up) requires only 5 minutes of net storage.

As demonstrated, the selection of the receiver size may vary based on the characteristics of the system.

Surge Tank Pump Selection & Sizing

What is a Surge Tank?

A surge tank is really another name for a boiler feed tank. It acts exactly like a boiler feed tank would except that it feeds a deaerator in lieu of a boiler. With a surge tank the make-up water is added into this tank and blended with the return water so as not to shock the deaerator with temperature and capacity variations. In addition the pumps on the surge tank must run continuously, pumping the water directly into the modulating transfer or make-up valve on the deaerator. The second transfer pump is a standby pump that is activated by a low-level switch on the deaerator. This standby pump runs automatically in case the lead pump fails or can't keep up.

A surge tank is not a condensate pump since a condensate pump turns on and off based on the water level in its receiver. When a condensate style unit is used as a surge tank, it defeats the entire purpose of a surge tank by allowing large variations in capacity and temperature into the system. The main purpose of the surge tank is to level out the transients or control the mood swings so the deaerator runs as smoothly as possible.

If controlling these variations in temperature were not important, there would be no need to use expensive controls that modulate on the deaerator.

What does a Surge Tank look like?

Since a surge tank is really another name for a boiler feed tank, as mentioned earlier, the tank can take many shapes and forms. The tank can be made out of stainless steel, cast iron (with a 20-year warranty against corrosion failure) to prevent against corrosion failure, or of black steel.

The surge tank can be an integral part of the deaerator, like a two-compartment style, or free standing by itself.

Also, the tank can be elevated or mounted on the floor like many of the types throughout the entire catalog. Yes, the surge tank may be placed on the floor. This is possible because at 150, 180 or even 200° F, the water temperature is low enough that NPSH is not a major concern. For example, with 194° F water you have 10.46 ft. of NPSH available. If you look at the pump curves in the catalog, the pumps, if properly selected, are 2 ft., 4 ft. or 6 ft. NPSH at the best efficient point on the curve. Hence, the NPSH available is greater than the pump NPSH requirement.

When is it used?

The general rules of thumb are as follows:

- On systems with **80% or more make-up** a surge tank is really not required.
- On systems with **more than 20% returns** a surge tank is required to achieve good deaeration.

How to Determine Transfer Pump (Gallons per Minute) GPM

All deaerator units are rated in lbs/hr of steam. The transfer pumps on the surge tank units are sized based on this rating. Lbs/hr divided by 500 equals the evaporation rate in GPM for these pumps. The pumps are sized as follows:

If transfer pumps are feeding a deaerator on a free-standing by itself surge tank (-2T) system, the pump rate in GPM equals the evaporation rate or the total load rating on the deaerator. For example, if deaerator system is rated 10,000 lbs/hr, then each transfer pump should be rated for 20 GPM.

If transfer pumps feeding a deaerator with the surge tank are part of the complete unit like our two-compartment model (-2C), the transfer pumps are sized differently based on being an atmospheric or pressurized deaerator.

If a pressurized two-compartment deaerator unit is used (-2C), the pump rate equals the evaporation rate or the total load rating on the deaerator (as mentioned earlier).

If an atmospheric two-compartment deaerator is used (.005 DA-2C or .03 DA-2C), the pump rate in GPM equals the evaporation rate of the deaerator multiplied by 1.5. For example, if deaerator is rated 10,000 lbs/hr, then each transfer pump should be rated for 30 GPM (20 GPM x 1.5). This is to allow recirculation of water through the vent condensers. *In addition, this is the only type of surge tank where NPSH is a concern and pumps should have an NPSH requirement lower than the height of the stand to be safe.*

Recirculation for these continuously running transfer pumps may be required. The SHIPCO® Model P and D pumps have as standard a bleed line that does not require any additional recirculation when pumping liquids lower in temperature than the saturation or boiling point.

How to Determine the Pump Discharge Pressure PSIG

The surge tank pumps are sized as follows:

- A) To overcome the operating pressure of the deaerator
- B) Spray nozzles
- C) Friction loss in pipe
- D) Vertical lift between deaerator and surge tank
- E) Safety margin generally 5 PSIG
- F) Pressure drop associated with transfer valve

The amount of these values, or these values added together, is normally expressed in feet of head. To convert to pounds per square inch, or PSIG, 2.31 ft. = 1 PSIG.

Generally the surge tank is located beside the deaerator or when it is part of the deaerator itself; therefore, a transfer pump discharge of 25 PSIG is

used as our standard since our standard transfer modulating valves are sized for 100% of the deaerator load with a 10 PSIG drop across valve.

Determine Receiver Size

The receiver on a surge tank is sized based on the total load of all boilers in the system, the same sizing as that of a standard boiler feed unit. The receiver size is based on 10 minutes of net storage as a general rule of thumb.

Boiler Feed Pumps

SHIPCO® offers a wide variety of boiler feed pump types with various models and styles designed specifically to pump hot condensate over a wide range of flow and pressure applications. Pumps are centrifugal single or multi-stage and can be vertical or horizontal flange mounted with 1750 RPM or 3500 RPM motors in single or three phase. Pumps are low NPSH designed bronze fitted with removable wear ring and impeller and equipped with industry standard motors that can be purchased locally.

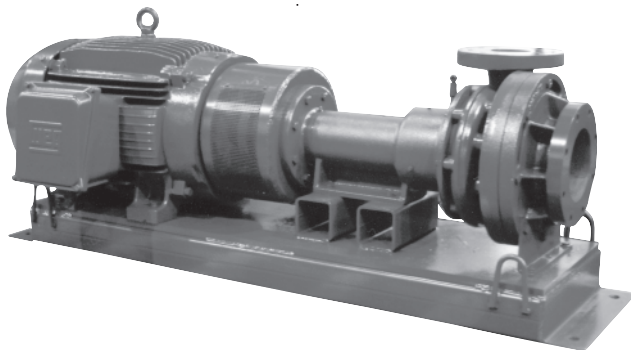

The pump design typically furnished on deaerators is a multi-stage, AWF style of pump. This pump is centrifugal, bronze-fitted design. Pump typically used for applications with flows up to 500 GPM and pressures up to 340 PSIG. Pump types (such as 221 AWF, 231 AWF, 616 AWF, etc.) selected depend on the design operating conditions—flow rate, discharge pressure and NPSH requirements; impellers trimmed to operating conditions. Pumps come standard with an ASA flanged suction and discharge. Pumps also have coupling guards. Pumps are furnished with bleed lines, sometimes called seal flushing lines, to help prevent the pump from vapor binding and to allow pump operation against a dead shut-off for a period of time without burning mechanical seals. Silicon carbide/Viton seals provided are for temperatures up to 300°F. All pumps come equipped with an automatic flow control valve for balancing or throttling pump to the designed condition point.

On all deaerator applications where pump is running continuously, an additional stainless steel bypass orifice must be installed when motor horsepower exceeds 7½ HP.

Why Do We Recommend 3500 RPM Centrifugal Pumps for Most Boiler Feed Applications?

- 1) More efficient than 1750 RPM for most condensate and boiler feed applications.
- 2) Operating and repair costs are lower because pumps are more efficient and the motors and parts are less expensive.
- 3) Less likely to overload motor than 1750 RPM pumps because of much steeper head—capacity, characteristic especially for small capacities. If actual head on the pump is lower than the design head, the pump will operate at higher capacities with accompanying higher power. The 3500 RPM pump maximum load is lower.
- 4) Just as durable as 1750 RPM centrifugal pumps for the same head and capacity. Centrifugal pumps are not subject to the wear problems of regenerative turbine pumps which are frequently chosen to run at 1750 RPM because of this inherent limitation.
- 5) NPSH requirements are low for the lower capacities and can be further reduced by use of the "P" modification for higher capacities where the NPSH available is unusually low.

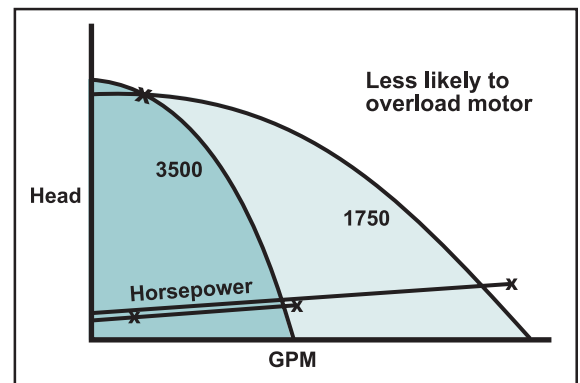

Are Suction Strainers Necessary on Centrifugal Pumps?

It is often asked whether a pump suction strainer is necessary or recommended. The purpose of a suction strainer is to act as a particulate strainer or filter ahead of the pump. This prevents large particles from entering the pump.

Before the introduction of the low-flow/high-head multi-stage centrifugal type pump, turbine type pumps were used almost exclusively for on/off boiler feed service for steam boilers. Back in the 1920s, a turbine pump was the only pump available for high-pressure pump applications since multi-stage, centrifugal pumps were not yet available. The turbine pump impeller was designed with very close tolerances within the pump. Any grit or sediment that entered the pump would result in accelerated erosion of these close-tolerance areas, leading to premature pump wear and loss of performance. These pump characteristics made the use of a strainer a necessity with a turbine type pump.

During the 1960s, ITT Domestic® and other manufacturers introduced multi-stage, centrifugal pumps into the high-pressure steam market. Then during the 1980s, manufacturers such as Grundfos, Gould, etc., started marketing multi-stage, centrifugal pumps and offering the pumps to boiler manufacturers who make feed tanks but not pumps. This strategy caused the boiler manufacturers to start specifying multi-stage, centrifugal pumps in lieu of turbines because the manufacturers now had a source for pumps.

Centrifugal pumps, by their design, are more durable. A centrifugal pump does not have the same close tolerances of a turbine pump—it has a more robust design that enables grit and sediment to pass through without clogging the impeller volute area. Therefore, the use of a suction strainer is neither mandatory nor recommended. Instead, an inlet basket on the return piping into the receiver and a wye strainer on the make up water piping are recommended.

Below is a list of considerations regarding the use of suction strainers with centrifugal pumps:

- **Suction Losses:** The addition of a strainer in the suction line of a pump increases the losses in the suction line, thereby decreasing the NPSH available to the pump. As the strainer

fills with particles, the pressure drop across the strainer increases, further reducing the NPSH available. This situation becomes more critical as the temperature of the pumped water increases. When a feed water pump is pumping from a deaerator, the water is already at the flash point, and any increase in the suction losses could lead to a flashing condition and pump cavitations.

- **Increased system maintenance:** Because of the reason stated above, it is important that the strainer screen be checked and cleaned regularly. If the installation is in a remote area and maintenance checks are rare, a clogged strainer will eventually lead to pump failure and a low water condition in the boiler.
- **Can particles get into the pump without a strainer?** SHIPCO® recommends use of inlet strainers on all deaerators and boiler feed tanks to help prevent particles from getting into the pump. In addition the suction piping typically extends 2" to 3" up into the receiver (often referred to as a vortex breaker). This extension helps prevent any sediment and large particles from leaving the tank through the suction opening. In SHIPCO® deaerators, the water entering the deaerator must travel through a series of spray valves, baffles, trays and other restricted flow paths before deaeration is complete and the water is ready for use. The number and size of the particles that will make it through this path and into the storage area are limited.

As the engineering community continues to improve its understanding of the functions of centrifugal and turbine pumps, engineers are starting to remove requirements for suction strainers from specifications.

SHIPCO® believes that any benefit of a suction strainer is far outweighed by the risks, which can lead to pump failures and other system problems.